



Display Chiller



Japanese equipped cooling system



Energy Efficient



Contact us

Mobile: +65 9125 8874 Fax: +65 6443 3825

E-mail: Sales@cube-refrigeration.com

www.cuberefrigeration.com

C+1DC

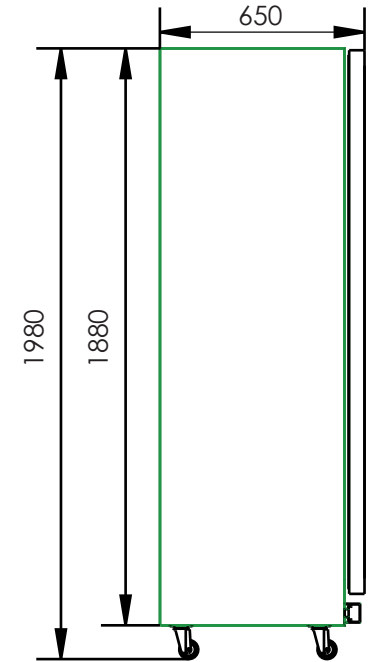
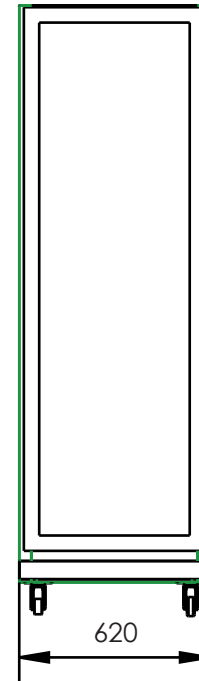

Product Size & Loading

Model	C+1DC
Voltage/frequency	220~240V/50HZ
Refrigerant	R290/134
Foaming agent	Cyclopentane
Climate class (N=16-32°C,ST=18-38°C,T=18-)	25°C 60%RH
Inner temperature	2°C ~ 8°C
Energy consumption (kWh/24h)	285W.H/24H
Capacity	420L
Product Dimension W x D x H (mm)	620*650*1980
Packing Dimension W x D x H (mm)	700*700*2200
Net /Gross weight (kg)	160/185
Door type	Hinged, self-closing

C+2DC

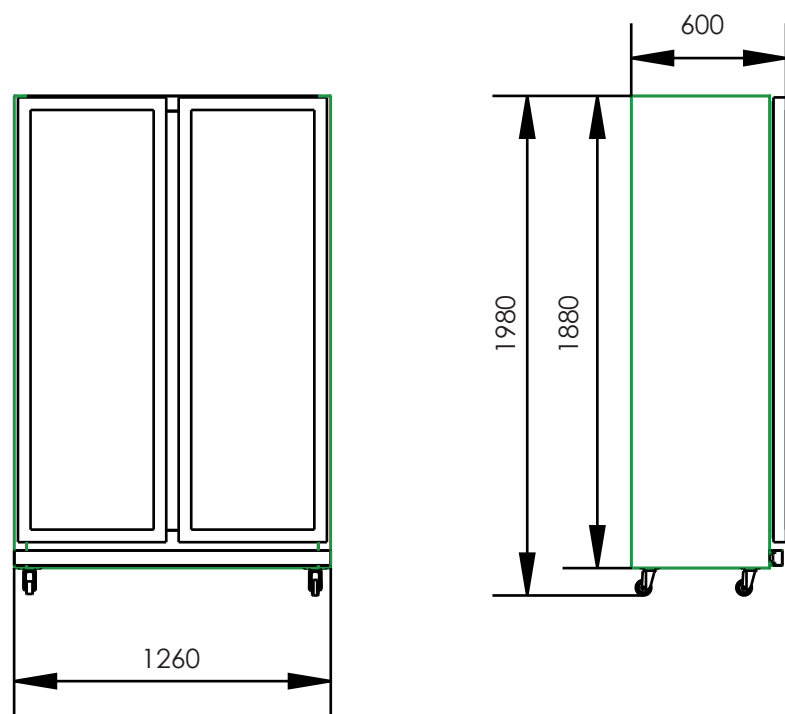

Product Size & Loading

Model	C+2DC
Voltage/frequency	220~240V/50HZ
Refrigerant	R290/134
Foaming agent	Cyclopentane
Climate class (N=16-32°C,ST=18-38°C,T=18-)	25°C 60%RH
Inner temperature	2°C ~ 8°C
Energy consumption (kWh/24h)	490W.H/24H
Capacity	1000L
Product Dimension W x D x H (mm)	1260*600*1980
Packing Dimension W x D x H (mm)	1300*700*2200
Net /Gross weight (kg)	185/210
Door type	Hinged, self-closing

C+3DC

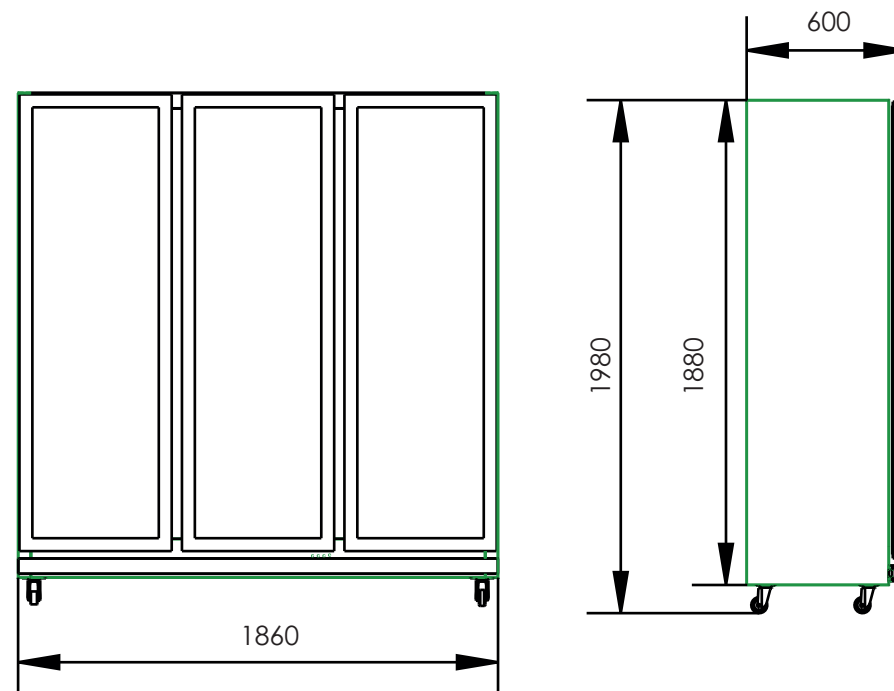

Product Size & Loading

Model	C+3DC
Voltage/frequency	220~240V/50HZ
Refrigerant	R290/134
Foaming agent	Cyclopentane
Climate class (N=16-32°C,ST=18-38°C,T=18-)	25°C 60%RH
Inner temperature	2°C ~ 8°C
Energy consumption (kWh/24h)	565W.H/24H
Capacity	1600L
Product Dimension W x D x H (mm)	1860*600*1980
Packing Dimension W x D x H (mm)	1900*700*2200
Net /Gross weight (kg)	210/250
Door type	Hinged, self-closing